

## Preserving the Harvest *Canning Fruit*

Organisms that cause food spoilage—molds, yeasts, and bacteria—are always present in air, water and soil. Enzymes that may cause undesirable changes in flavor, color and texture are present in raw fruits.

When fruits are canned, they are heated hot enough and long enough to destroy spoilage organisms. This heating (or processing) also stops the action of enzymes that can spoil food quality. Because fruits have a high acid content, processing can be done in a boiling water bath canner. Fruits can also be processed in a pressure canner, but it can take more time overall due to steps added for venting air from the pressure canner, pressurizing the canner, and cooling the canner before removing jars. For directions for canning fruits in a pressure canner, call your county Extension office.

### **Equipment**

*Boiling water canners* are available in several types of stores or through Internet sales. Any big metal pot may be used as a boiling water bath canner if it is deep enough so the water can cover the jars by at least one inch and still have ample room for boiling (two or four inches above jar tops - see illustration). The canner must have a tight-fitting cover and wire or flat metal rack with plenty of open spaces in it.

A pressure canner may be used for a boiling water bath canner, provided it is deep enough. Make sure the lid is securely on the bottom, but do not fasten or twist-tighten the cover. Leave the vent pipe open so steam can escape and pressure does not build up in the canner.

*Canning jars* should be checked closely for signs of cracks or chips. Jars specifically designed for home canning are best. Commercial food jars such as mayonnaise or coffee jars break easily and may not seal. Use only the half-pint, pint or quart sizes for fruits as specified with processing directions. Half-gallon jars may also be used for very acid, thin juices. Jars should be checked closely for cracks, nicks or chips. Wash jars in hot, soapy water, rinse well, and keep hot until filled and placed in the canner.

If jars will be processed in a boiling water bath for less than 10 minutes, they need to be pre-sterilized by boiling them completely submerged in boiling water for 10 minutes. (If you are at an altitude of 1000 feet or more, add 1 minute of sterilizing time for each 1000 feet of altitude.) Then keep the jars hot until they are used; this can be done by leaving them in the water from boiling. This will prevent the containers from breaking when filled with the hot product. Jars processed in a boiling water bath for 10 minutes or more, or in a pressure canner, will be sterilized during processing and do not need prior sterilization. They do need to be washed in hot, soapy water, rinsed and then kept hot until filled and placed in the canner.

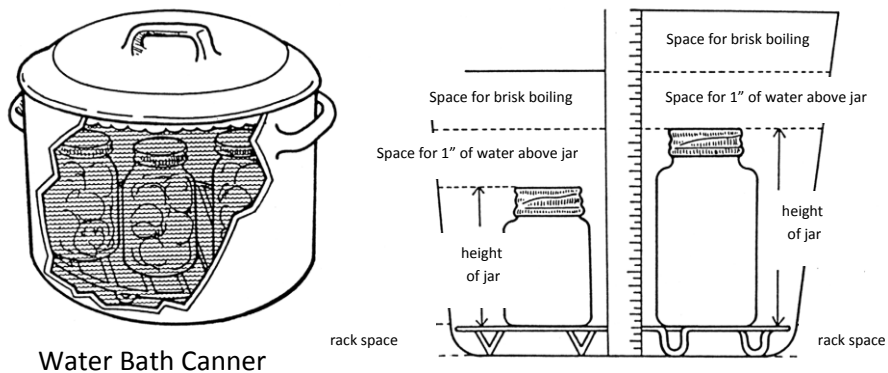

Water Bath Canner

*Two-piece metal canning lids* need to be prepared for use. The flat lids can be used only once for sealing new products, but the ring bands can be reused as long as they are in good condition. Pretreat the new flat lids as directed by the manufacturer. Do not reuse lids from commercially canned foods for home canning.

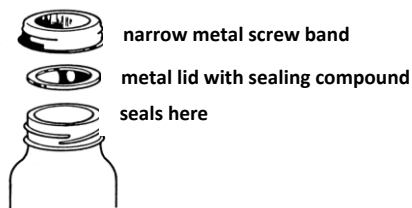

### Preparing the Fruit

Choose fresh, firm fruits of best eating quality. The faster you can get them from the garden to the jar, the better. If you buy fruits to can, try to get them from a nearby garden or orchard. For even cooking, sort the fruits for size and ripeness. Rinse and clean all fruits thoroughly, whether or not they are to be pared. Dirt contains some of the bacteria hardest to kill. Do not let fruits soak; they may lose flavor and nutrients. Handle them gently to avoid bruising.

**To prevent darkening** – Some peeled or cut fruits darken when exposed to air. Any of these simple treatments will help prevent darkening.

1. Drop the fruit in a solution made from 1 teaspoon or 3000 mg ascorbic acid (vitamin C) and 1 gallon of water. (Crush tablets thoroughly.)
2. Use a commercial ascorbic acid mixture, available in grocery stores and drug stores, according to instructions on the container. Hold the peeled and cut fruit in one of these solutions until you are ready to heat and/or raw pack the fruit. Then drain the fruit well.

### Canning Liquids for Fruits

Fruits may be canned in water, juice or a sweet syrup. The sweet syrup helps the fruit hold its shape, color and flavor but does not preserve the fruit. Directions for canning each fruit will specify the canning liquid that is usually most popular or that results in a finished product most like the commercially-canned fruit. Most canning liquids contain sugar. However, you may want to experiment. You may be pleased with a water, juice or lighter syrup-packed product.

**Syrup Packs** – Sugar syrup is made by mixing water or juice extracted from some of the fruit (see “Juice Packs”) with sugar. The mixture is heated to dissolve the sugar and is kept very hot until ready for use. Choose one of the syrups given in the chart below, to suit the sweetness of the fruit and your own taste.

**Juice Packs** – Commercial unsweetened apple juice, pineapple juice or white grape juice make good packing liquids for many fruits. These may be used as is or diluted with water. Juice can also be extracted from some of the fruit that is being canned or from fresh apples, pineapple or white grapes.

**To extract juice** – Thoroughly crush ripe but food quality fruit. Heat to simmering over low heat. Let drip through cheesecloth or a jelly bag.

### Artificial Sweeteners

These non-sugar sweeteners will only add sweetness to the canned fruit. The texture and other preserving aspects of a sugar syrup will not be provided. The result would be like canning in water except for the additional sweetness contributed by the sweetener. It is best to add many of

### Syrups for Use in Canning Fruits

Type of syrup	Percent sugar*	Cups of Sugar** Per Quart of Liquid	Yield of Syrup in Cups*	How Syrup is used Commercially
Very light	10%	½	4 ½	
Light	20%	1	4 ¾	Very sweet fruit
Medium	30%	1 ¾	5	Sweet apples, sweet cherries, berries, grapes
Heavy	40%	2 ¾	5 1/3	Tart apples, apricots, sour cherries, gooseberries, nectarines, peaches, pears, plums
Very Heavy	50%	4	6	Very sour fruit

\* Approximate.

\*\* In general, up to one-half of the sugar may be replaced by corn syrup or mild flavored honey. A larger proportion of corn syrup may be used if a very bland, light-colored type is selected.

these just before serving the fruit. Saccharin-based sweeteners can turn bitter during processing. Aspartame-based sweeteners lose their sweetening power during processing. Granular sucralose, however, can be used for sweetening the water used to cover fruits when canning. Some people may notice an aftertaste in the canned fruits, but for people used to sucralose sweetening, the aftertaste may not be an issue. It may be preferable to try less than a full one-to-one measured substitution when replacing sugar in canning syrups; many people are satisfied with using one-half the amount of sugar in a medium syrup recipe measured as sucralose. More sweetening can always be added when you serve the finished product if it is not sweet enough. You can increase the amount of sucralose the next time you can if you desire additional sweetness.

### ***Filling the Jars***

Fruits may be packed raw into jars or preheated and packed hot. Read the directions for each fruit to determine which methods may be used. Remember, have the clean or pre-sterilized jars hot to prevent breakage as they are filled.

**To raw pack** – Put prepared raw fruits into jars and cover with very- or boiling-hot syrup, juice or water. Most raw fruits should be packed tightly into the jars because they shrink during processing.

**To hot pack** – Heat prepared fruits in syrup, water or juice before packing. Pack hot food loosely. Food should be at or near boiling temperature when it is packed unless specific directions indicate another preparation.

For either pack, use enough syrup, water or juice to fill around the solid food in the jar and to cover the food. See directions for each fruit for the correct amount of headspace to leave between the top of the food and the top of the jar. This headspace is important for obtaining a good seal.

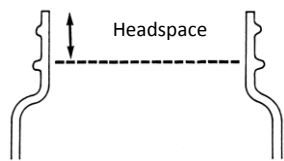

### ***Closing the Jars***

To remove any trapped air bubbles, slide a non-metallic (eg., plastic) spatula between the food and obtain the proper headspace. Wipe the jar rim with a clean damp paper towel to remove any food particles or liquids. Place the flat lid prepared according to the manufacturer's directions on the filled jar. Screw the metal ring band down fingertip tight.

### ***To Process Fruits***

\* Fill the canner at least half full with clean hot water. Enough water is needed so that the level will be 1-2 inches over the tops of the jars after they are added. Center the canner over the burner and preheat the water to about 180°F (simmering) for hot packs and hot but not yet simmering (about 140°F) for raw packs.

\* Using a canning jar lifter, place filled jars on a rack in the canner containing hot or simmering water. Make sure the jar lifter is securely positioned below the neck of the jar and ring band and keep the jar upright at all times. Tilting the jar could cause food or covering liquid to spill into the sealing area of the lid.

\* Add boiling water if needed to bring water to a level one or two inches over the top of the jars, pouring it between the jars and not directly on them. Put the cover on the canner. Turn the burner to its highest heat setting and bring the water in the canner to a full boil.

\* When the water in the canner comes to a rolling boil, start to count processing time. Boil gently and steadily for the time recommended for the food being canned. Add boiling water during processing if it's needed to keep jars covered. If the water stops boiling at any time during the process, bring the water back to a boil and begin the timing of the process over, from the beginning.

\* When the jars have been processed for the recommended time, turn off the heat and remove the canner lid. Turn the lid so the steam escapes away from your face. Wait 5 minutes before removing jars.

\* Using a jar lifter, remove the jars, being careful not to tilt them. Carefully place the jars right side up on a rack or dry towels to prevent jars from breaking on contact with a cold surface. Leave at least one inch of space between jars during cooling.

\* Allow the jars to cool undisturbed, away from drafts, for 12 to 24 hours. Do not tighten ring bands on the lids or push down on the center of the lid until the lid is completely cooled. Even if a popping sound is heard as lids seal, leave the jar and lid untouched until completely cool.

### ***Day-After-Canning Jobs***

Test the seal on the jar lids. Press flat metal lids at the center. They should be slightly concave and not move. Ring bands should be removed from thoroughly cooled jars; wash and dry them so they will be in good condition after storing. Wash food residue from the jars and rinse. Label sealed jars with contents and date.

Store the canned food in a cool, dry place. Stored properly, canned fruits should retain their high quality for about one year.

Treat unsealed jars of food as fresh. The food can be eaten immediately, refrigerated, frozen or recanned. If you recan the food, the whole processing time must be repeated.

### *On Guard Against Spoilage*

Do not taste or use food that shows any signs of spoilage. Look closely at all jars before opening them. A bulging lid or leaking jar is a sign of spoilage. When you open a jar, look for other signs such as spurting liquid, an off odor or mold. Dispose of all spoiled canned fruit in a place where it will not be eaten by children or pets.

## Directions for Canning Fruits

### Preparation methods and processing Times for Canning in a Boil Water Bath

**Caution! Altitude Adjustments:** The processing times given here are those recommended for altitudes of 0-1000 feet. If you are canning at an altitude over 1000 feet, see the last page for adjusted processing times. **DO NOT DECREASE** the processing times given.

Fruit	Pack	Preparation	Processing Time (Minutes)	
Apple juice	Hot	For best results, buy fresh juice from a local cider maker within 24 hours after it has been pressed or press your own. Refrigerate juice for 24 to 48 hours. Without mixing, carefully pour off clear liquid and discard sediment. Strain clear liquid through a paper coffee filter or double layer of damp cheesecloth. Sterilize jars. Heat juice, stirring occasionally, until juice begins to boil. Pour into hot jars, leaving ¼ inch headspace.	Pints Quarts Half-gallon	5 5 10
Apples	Hot	Make a very light, light or medium syrup. Wash, peel, core and slice apples. Treat to prevent darkening. Remove sliced apples from anti-darkening solution, drain and place in a large saucepan. Add 1 pint syrup, water or juice per 5 pounds apples. Boil 5 minutes, stirring occasionally. Pack hot apples into hot jars, leaving ½ inch headspace. Fill jar to ½ inch from top with hot syrup	Pints Quarts	20 20
Applesauce	Hot	Wash, peel and core apples. Treat to prevent darkening. Remove slices from anti-darkening solution and place drained slices in an 8- to 10-quart pot. Add ½ cup water. Stirring occasionally to prevent burning, heat quickly and cook until tender (5 to 20 minutes, depending on maturity and variety). Press through a sieve or food mill, if desired. If you prefer chunk-style sauce, omit the pressing step. If desired, add 1/8 cup sugar per quart of sauce. Reheat sauce to boiling. Pack into hot jars, leaving ½-inch headspace.	Pints Quarts	15 20
Apricots		Follow directions and processing times for peaches.		
Berries (except strawberries and cranberries)	Hot	Berries may be canned in water, juice or syrup. Prepare and heat the liquid of your choice. Wash, drain, cap and stem if necessary. For gooseberries, snip off heads and tails with scissors.  Use this method for blueberries, currants, elderberries, gooseberries and huckleberries. Heat to boiling, about 1 gallon of water for each pound of berries. Blanch berries in boiling water for 30 seconds. Drain. Place ½ cup of hot syrup, juice or water in each hot jar. Pack hot berries into hot jars, leaving 1/2-inch headspace. Fill jars to ½ inch from the top with more hot syrup, juice, or water.	Pints Quarts	15 20
	Raw	Use this method for any of the berries. Place ½ cup of hot syrup, juice or water in each hot jar. Fill jars to ½ inch from the top with	Pints Quarts	15 20

		raw berries, shaking gently while filling. Add more hot syrup, juice or water, leaving ½-inch headspace.		
Cherries	Hot	Stem and wash cherries. Remove pits if desired. If pitted, treat to prevent darkening. If cherries are canned unpitted, prick the skins on opposite sides with a clean needle to prevent splitting. Cherries may be canned in water, apple juice, white grape juice or syrup. Heat to boiling the liquid of your choice.  In a large saucepan add ½ cup water, juice or syrup to each quart of drained fruit. Bring to a boil. Pack cherries in hot jars, leaving 1/2-inch headspace. Fill jar to ½ inch from top with hot liquid.	Pints Quarts	15 20
	Raw	Add ½ cup hot water, juice or syrup to each hot jar. Fill jars to ½ inch from the top with drained cherries, shaking down gently as you fill. Add more hot liquid, leaving ½ inch headspace.	Pints Quarts	25 25
Fruit puree	Hot	<b>CAUTION:</b> These recommendations are <b>NOT</b> to be used with Asian pears, figs, tomatoes, cantaloupe and other melons, papaya, ripe mango or coconut.  Stem, wash, drain, peel and remove pits, if necessary. Measure fruit into large saucepan, crushing slightly. If desired. Add 1 cup hot water for each quart of fruit. Cook slowly until fruit is soft, stirring frequently. Press through sieve or food mill. If desired, add sugar to taste. Reheat pulp to boiling. If sugar was added, boil until it dissolves. Pack puree into hot jars, leaving ¼-inch headspace.	Pints Quarts	15 15
Peaches	Hot	Peaches can be packed in very light, light or medium syrup. They can also be packed in water, apple juice or white grape juice. Prepare the liquid and keep it hot. Dip fruit in boiling water for 30 to 60 seconds until the skins loosen. Dip quickly in cold water and slip off the skins. Cut in half, remove the pits and slice if desired. Treat to prevent darkening.  Remove slices from anti-darkening solution and drain well. In a large saucepan heat the drained fruit in syrup, water or juice to a boil. Pack hot fruit into hot jars leaving ½-inch headspace. When packing halves, place them cut side down. Fill jars to ½ inch from the top with hot liquid.	Pints Quarts	20 25
	Raw	Remove slices from the anti-darkening solution and drain well. Pack raw fruit into hot jars, leaving ½-inch headspace. When packing halves, place them cut side down. Fill jars with hot liquid, to ½ inch from the top.	Pints Quarts	25 30
Pears	Hot	Prepare a very light, light or medium syrup or heat apple juice, white grape juice or water. Wash and peel pears; cut lengthwise in halves and remove core. A melon baller or metal measuring spoon is suitable for coring pears. Treat to prevent darkening. Remove slices from the anti-darkening solution; drain well. Boil drained pears 5 minutes in syrup, juice or water. Pack hot pears into hot jars, leaving ½-inch headspace. Fill jars to ½ inch from top with liquid.	Pints Quarts	20 25

Fruit	Pack	Preparation	Processing Time (Minutes)	
Plums		Prepare a very light, light or medium syrup. Stem and wash the plums. To can whole, prick the skins on two sides of the plums with a fork to prevent splitting. Freestone varieties may be halved and pitted.		
	Hot	Add plums to hot syrup and boil for 2 minutes. Cover saucepan and let stand 20 to 30 minutes. Pack hot plums into hot jars, leaving ½ inch headspace. Fill jars with hot syrup to ½ inch from the top.	Pints Quarts	20 25
	Raw	Pack raw plums firmly into hot jars, leaving ½-inch headspace. Fill jars with hot syrup to ½ inch from the top.	Pints Quarts	20 25

### Boiling Water Bath Processing Times for Fruits at Altitudes over 1,000 Feet

Fruit	Pack Style	Jar Size	Processing Time (Minutes) at Altitudes of		
			1001-3000 feet	3001 – 6000 feet	over 6000 feet
Apple juice	Hot	Pints or Quarts	10	10	15
		Half-gallons	15	15	20
Apples	Hot	Pints or Quarts	25	30	35
Applesauce	Hot	Pints	20	20	25
		Quarts	25	30	35
Berries	Hot	Pints or Quarts	20	20	25
	Raw	Pints	20	20	25
		Quarts	25	30	35
Cherries	Hot	Pints	20	20	25
		Quarts	25	30	35
	Raw	Pints or Quarts	30	35	40
Fruit Puree	Hot	Pints or Quarts	20	20	25
Peaches or Apricots	Hot	Pints	25	30	35
		Quarts	30	35	40
	Raw	Pints	30	35	40
		Quarts	35	40	45
Pears	Hot	Pints	25	30	35
		Quarts	30	35	40
Plums	Raw or Hot	Pints	25	30	35
		Quarts	30	35	40

**Authors:** Elizabeth L. Andress, Ph.D., and Judy A. Harrison, Ph.D., Extension Foods Specialists, The University of Georgia Cooperative Extension. Reprinted with permission from the University of Georgia. Revised 07-10